

EV-39 N

Model	EV-39N	
Rated output	Kw(ps)	91.2(124)
	rpm	2919
Max. Torque	kgf.m(Nm)	36.6(359)
	rpm	1606
Compression ratio	11.5:1	
Displacement (l)	3.907	
No. of cylinder	4 - inline	
Aspiration	Turbo & Intercooler	
Combustion type	Lean Burn	
Fuel	CNG	
Dimension(mm)	822 x 800 x 800	
Dry Weight(kg)	350	
Flywheel	PCD Φ 350, 10-M10x1.5	
Flywheel Housing	PCD Φ 429.1, 13-M10x1.5	

Engine Configuration & Dimensions

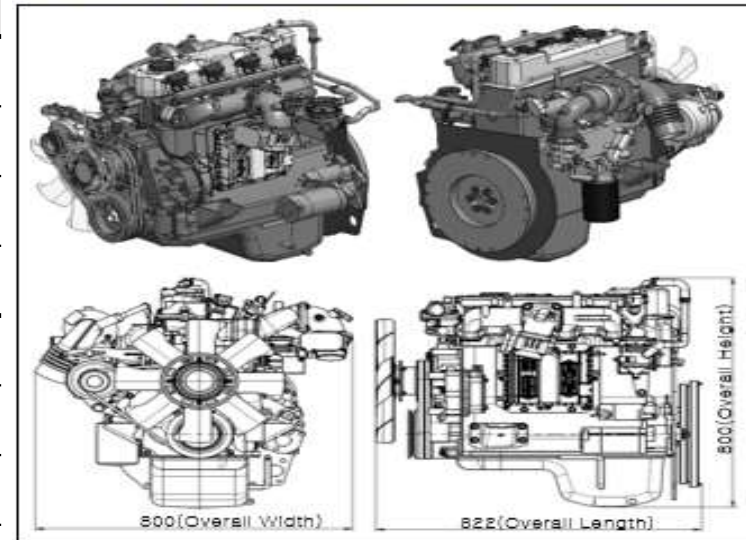

Performance Curve

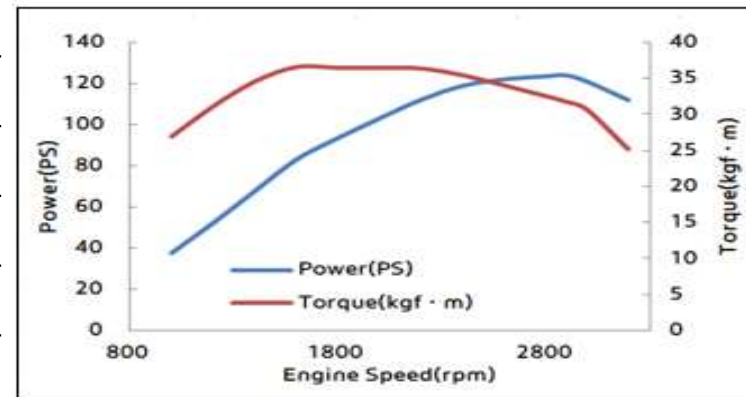

The engine performance corresponds to ISO 3046 (Without cooling fan). The product images shown are for illustration only and may not be an exact representation of the final product. All information is subject to change without notice.